

818 Reference Audio Core User Guide



Important safety instructions

- Read the instructions.
- Keep these instructions.
- Follow all instructions.
- Do not use this apparatus near water.
- Clean only with a dry cloth.
- Install only in accordance with the manufacturer's instructions.
- Refer all servicing to approved service personnel.

WARNING: TO REDUCE THE RISK OF FIRE OR ELECTRIC SHOCK, DO NOT EXPOSE THIS APPARATUS TO RAIN OR MOISTURE.

This apparatus has been designed with Class 1 construction and must be connected to a mains socket outlet with a protective earthing connection (the third grounding pin).

This apparatus uses a single-pole power switch. As a result it is not isolated from AC mains power when switched off at the rear panel. The apparatus may be isolated from mains power either by unplugging the power connector from the rear of the unit, or by unplugging the connector at the opposing end of the power cord or cable from its supply outlet. As a result, either or both of these connectors should remain accessible.

Safety warnings

- Do not expose the unit to dripping or splashing.
- Do not place any object filled with liquid, such as a vase, on the unit.
- Do not place naked flame sources, such as lighted candles, on the unit.

To avoid overheating

- Leave at least 10cm around the equipment to ensure sufficient ventilation.

Do not position the unit:

- In direct sunlight.
- Near heat sources, such as a radiator.
- Directly on top of heat producing equipment, such as a power amplifier.

To avoid interference

Do not position the unit:

- Near strong electrical or magnetic radiation, such as near a power amplifier.

Radio interference

FCC Warning: This equipment generates and can radiate radio frequency energy and if not installed and used correctly in accordance with our instructions may cause interference to radio communications or radio and television reception. It has been type-tested and complies with the limits set out in Subpart J, Part 15 of FCC rules for a Class B computing device. These limits are intended to provide reasonable protection against such interference in home installations.

EEC: This product has been designed and type-tested to comply with the limits set out in EN55013 and EN55020.



Contents

Introduction	1	Installing the 818 Reference Audio Core	21
The 818 Reference Audio Core	2	Unpacking	22
Specifications	4	Applications	24
Using the 818 Reference Audio Core	5	Configuring the 818 Reference Audio Core	33
Front panel keys	6	Choosing a standard setting	34
MSR+ keys	7	Setup parameters	35
Switching on and off	8	Setting the startup volume	36
Selecting a source	9	Setting the output mode and SpeakerLink setting	37
Adjusting the system volume	10	Configuring the EBC settings	38
Changing the treble, bass, or balance	11	Muting the analogue relay	39
Changing the axis or phase	12	Installing the Meridian Configuration Application	40
Adjusting the sensitivity of sources	13	Index	41
Changing the front-panel display	14		
Headphone mode	15		
Using the SpeakerLink controls	17		
Primary SpeakerLink controls	18		
Subwoofer setup controls	19		

Copyright and acknowledgements

Sales and service in the UK

Meridian Audio Ltd
Latham Road
Huntingdon
Cambridgeshire
PE29 6YE
England

Tel (01480) 445678
Fax (01480) 445686

Designed and manufactured in the UK

Visit us on the Web

www.meridian-audio.com

Copyright © 1999-2015 Meridian Audio Ltd.

Part no: 818U/3 (P88443)

MHR: this product incorporates copyright protection technology covered by certain patent applications and intellectual property of Meridian Audio Ltd. This technology is provided for the express purpose of securely containing copyright audio within the Meridian System only. Reverse engineering or circumvention of this protection is strictly prohibited.

BoothroydStuart Meridian, Meridian, and Sooloos are registered trademarks of Meridian Audio Ltd.

This guide was produced by:
Human-Computer Interface Ltd,
www.interface.co.uk

Product registration

Register your Meridian 818 Reference Audio Core at:
www.meridian-audio.com/support

Introduction

Welcome to the Meridian 818 Reference Audio Core.

This User Guide provides full information about using the 818 in conjunction with your other equipment, to achieve the superb results you can expect from it.



The 818 Reference Audio Core

Incorporating the advanced technology from Meridian's popular 808 Signature Reference CD Player, the Meridian 818 Reference Audio Core is a stereo audio controller with a wide range of digital and analogue inputs.

Outputs

The 818 Reference Audio Core provides two Meridian SpeakerLink connectors for simple, straightforward connection to Meridian DSP Loudspeakers via Cat 5 cables.

Alternatively, balanced and unbalanced analogue outputs are provided for connecting to an external power amplifier or preamplifier.

If you are using DSP loudspeakers you can connect a headphone amplifier, such as the Meridian Prime Headphone Amplifier, to the analogue outputs for headphone listening. A headphone mode is provided to mute the loudspeakers when listening on headphones.

Inputs

On the input side, the 818 Reference Audio Core provides a wide range of possibilities.

The 818 Reference Audio Core provides a network socket to connect directly to a Sooloos network, allowing it to play music from and control a Sooloos Digital Media System.

A SpeakerLink input is provided for connecting to other Meridian sources with SpeakerLink outputs. In addition, two digital coaxial S/PDIF inputs and two Toslink optical digital inputs are provided, for connecting to other digital sources.

A USB B-type connector is provided to allow the 818 Reference Audio Core to be connected to a computer system and used as an external sound card.

Six stereo analogue inputs are provided on gold-plated phono connectors.

Audio processing

The 818 Reference Audio Core features high-quality audio processing. Analogue inputs are converted to digital at 96kHz sampling, and digital inputs accept signals up to 192kHz. High resolution files may be replayed from a Meridian Sooloos Digital Media System or a computer connected to the USB input.

Signals are processed with Meridian's exclusive apodising filter that ensures maximum audio quality with outputs at 96kHz/24 bit (digital) or 192kHz/24 bit (analogue).

The 818 Reference Audio Core will also decode MQA (Master Quality Authenticated) audio streams. It can extract the finest of details from music and deliver the audio for rendering either to its own analogue outputs, or to an attached DSP loudspeaker system. The front panel display will indicate MQA as will any attached DSP loudspeaker system that can recognise the stream.

When used with analogue loudspeakers the 818 Reference Audio Core can provide tone adjustments as well as balance and volume controls.

When used with Meridian DSP Speakers, the 818 Reference Audio Core provides control of additional audio processing in the speakers, such as treble and bass tone controls and enhanced room boundary equalisation.

System integration

An RS232 interface provides full remote control capability as well as the ability to configure the unit with Meridian's innovative Windows-based graphic configuration application.

Three programmable trigger outputs are provided for direct control of external devices, for example powering-up amplifiers, etc.

The 818 Reference Audio Core is supplied with the MSR+ learning/programmable remote control, which not only operates all Meridian products but also includes an extensive database of third-party products and the capability to learn commands from existing remotes.

Specifications

Audio outputs

- 2-channel balanced audio output, driven by a 192kHz digital to analogue converter.
- 2-channel unbalanced audio output, driven by a 192kHz digital to analogue converter.
- 2-channel digital coax output.
- Two 2-channel Meridian SpeakerLink outputs.
- Optional MHR encryption on digital outputs at high rate.

Audio inputs

- Six 2-channel unbalanced analogue inputs. Adjustable sensitivity.
- Two 2-channel digital coax inputs. 44.1kHz to 192kHz sampling and up to 24-bit precision.
- One 2-channel Meridian SpeakerLink input. 44.1kHz to 192kHz sampling and up to 24-bit precision.
- Two 2-channel digital optical inputs. 44.1kHz to 96kHz sampling and up to 24-bit precision.
- One network input (Ethernet) for connection to a Meridian Sooloos Digital Media System.
- One USB input, for connection to a computer. Up to 192kHz sampling and up to 24-bit precision.
- All inputs provide renameable legends.

Signal processing

The 818 uses Meridian's proprietary DSP software to provide the following powerful features:

- Apodising filter.
- Upsampling.
- FIFO and error correction.
- Resolution enhancement.
- MQA decoding and rendering.

Controls

Front-panel facia controls for:

- Source, Play/Pause, Previous, Next, Mute, Volume Up and Down, and On/Off.

A hinged control panel provides additional controls for:

- Volume +/-, Source, Display, Mute, Setup, Fast Forward/Reverse, and Menu keys.

Display

- 20-character dot-matrix display with adjustable brightness and contrast.
- Indicators for Emphasis and Phase.

Using the 818 Reference Audio Core

This chapter provides a summary of the functions of the 818 Reference Audio Core to identify the controls you use to operate the unit.

It also provides step-by-step instructions for operating the 818, using either the front panel or the MSR+.



Front panel keys

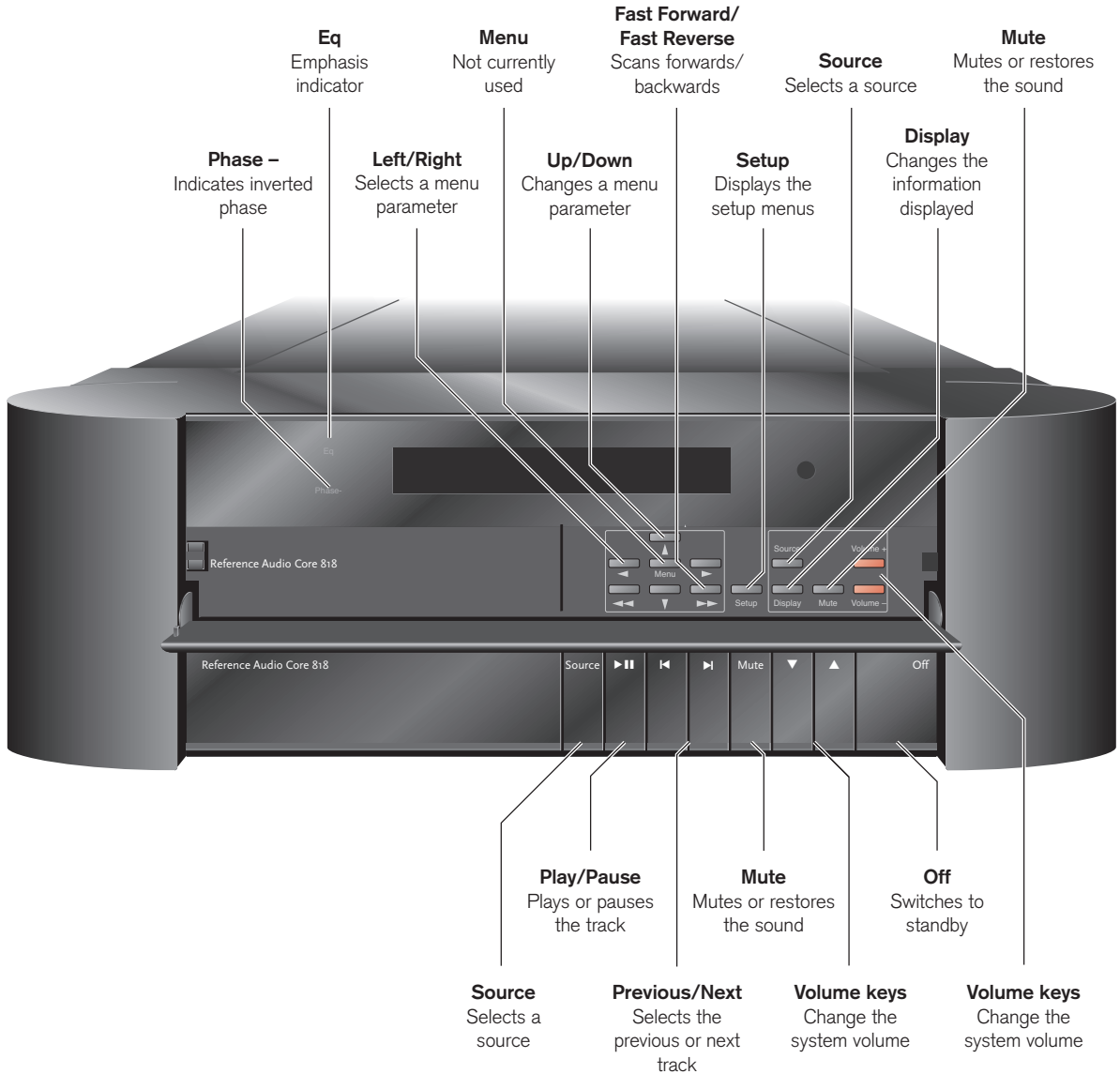

MSR+ keys

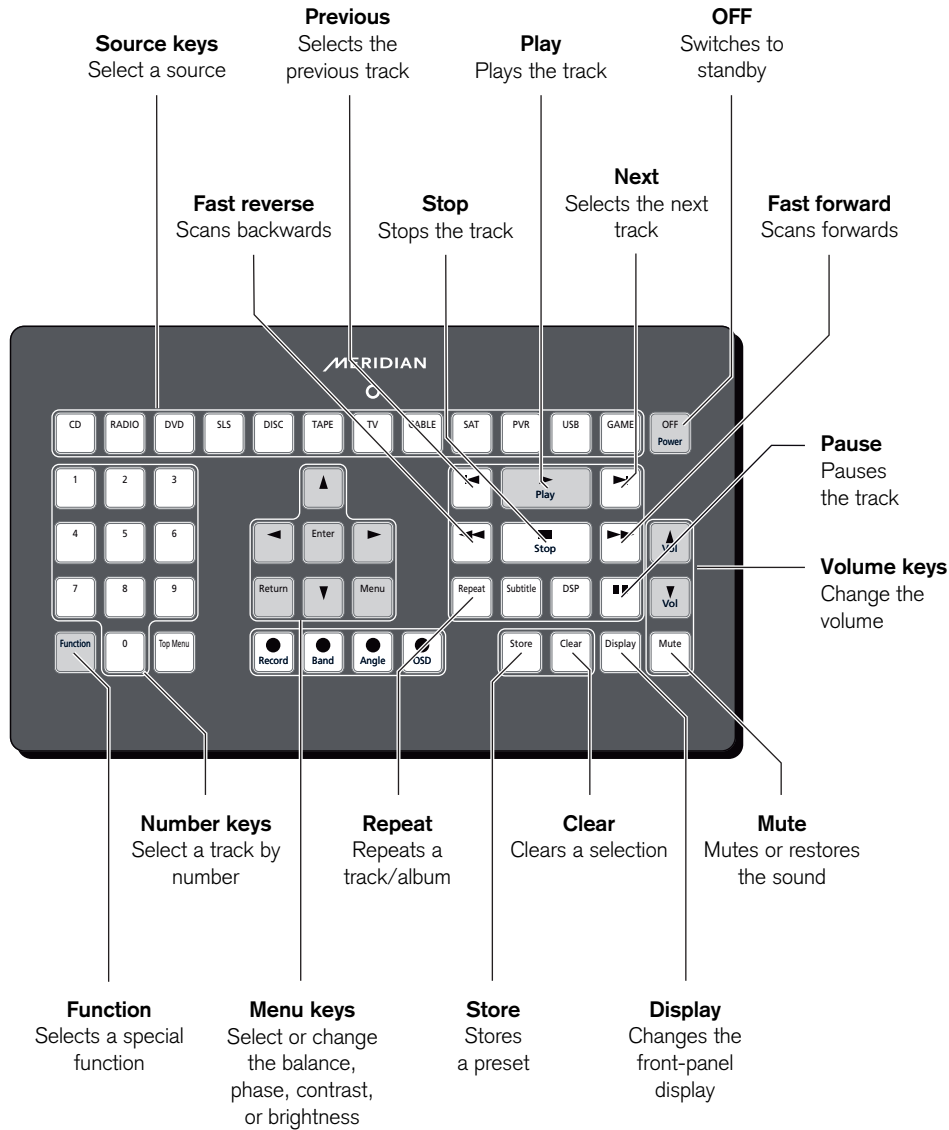

Switching on and off

When not playing, the 818 should be left in the standby state. This uses a minimal amount of electricity, but ensures that the components of the 818 operate at maximum efficiency from the moment you start.

If you are not going to use the 818 for several days you should switch the unit off completely at the rear panel, and disconnect it from the AC power supply.

To switch on from standby

- Press **Source** (front panel), or select a source on the remote.

If the 818 is part of a Meridian system it will automatically switch on any other units in the system, such as the 861 Reference Digital Surround Controller and Meridian DSP Loudspeakers.

To switch to standby

- Press **Off** (front panel or remote).

If you have other Meridian equipment or Meridian DSP Loudspeakers connected to the 818 these units will also switch to standby.

Selecting a source

The 818 responds to the following 12 source keys on the remote:

CD, Radio, DVD, SLS, Disc, Tape, TV, Cable, Sat, PVR, USB, and Game.

The input associated with each of the sources depends on how the 818 has been set up; for more information refer to the *Meridian Configuration Program Guide*.

Your installer may have customised the labels displayed for each source to suit your other equipment.

To select a source

- Press **Source** (front panel or under the front panel) until the display shows the source you want, or press the appropriate source key on the remote; eg **CD**.

The display shows the source and volume setting.

For example, if you select the Radio source:

The display shows:



The 818 mutes the sound while you change source.

To play music from a Sooloos system

Either:

- Press **Source** (front panel or under the front panel) until the display shows SLS, or press the **SLS** key on the remote.

Or:

- Select the 818 zone from the Sooloos controller.

You can then listen to music streamed from the Sooloos server.

The volume and mute controls on the Sooloos controller will operate the 818.

To control the Sooloos system

When the SLS source is selected you can control the Sooloos system from the 818 front panel controls.

- Press **▶|||** (front panel) or **■, |||, and ▶** (remote) to control playback.
- Press **◀** or **▶** (front panel or remote) to step between tracks in the Sooloos play queue.

For more information please refer to the *Meridian Sooloos Network Card Guide*.

Adjusting the system volume

The 818 Reference Audio Core provides a volume control which can be adjusted from the front panel or remote control. The volume changes in precise steps of 1dB, where 9dB is equivalent to doubling the loudness. The current volume setting is displayed in dB on the front-panel display, and can be varied in the range 1 to 99dB.

You can choose what startup volume is set when you switch the 818 on; see *To set the startup volume*, page 36.

If the 818 is set up with variable outputs (see [Choosing a standard setting](#), page 34) the analogue output level is varied, allowing the 818 to drive an amplifier or active loudspeakers. If the 818 is set up with fixed outputs the volume control is performed by the DSP loudspeakers.

To change the volume

- Press **Volume ▲** or **Volume ▼** (front panel), **Volume +** or **Volume -** (under the front panel), or the red **▲** or **▼** keys on the remote.

As you adjust the volume setting the display shows the current volume level.

For example:

A black rectangular display with white text. On the left, it shows 'CD' and on the right, it shows '65'.

To mute the sound

- Press **Mute** (front panel, remote, or under the front panel).

The display shows:

A black rectangular display with white text showing the word 'Mute'.

To restore the sound

- Press **Mute** again.

Alternatively, the sound will be restored if you adjust the volume.

Changing the treble, bass, or balance

The 818 Reference Audio Core provides sophisticated treble and bass controls, to allow you to adjust the broad balance of the sound to correct for the acoustics of your listening room, or for a misbalanced recording.

The controls are more subtle than conventional tone controls, and take advantage of digital signal processing techniques to provide a more natural adjustment of the frequency response.

The balance control uses digital signal processing to compensate for an off-centre listening position by delaying and diminishing the sound in one speaker, thus effectively shifting the speaker's image back.

These controls only affect the analogue outputs when the 818 Reference Audio Core is set up with variable outputs.

To change the treble

- Press ◀ or ▶ (remote or under the front panel) until the display shows the current treble.

For example:

SLS Treble +1.0

- Press ▲ or ▼ (remote or under the front panel) to change the treble.

The treble control tilts the frequency of the response over the entire frequency range to make the sound brighter or dimmer. It can be adjusted between ± 10 db in 0.5dB steps. Normally settings between +1.0 and -2.0 will give the most natural results.

To change the bass

- Press ◀ or ▶ (remote or under the front panel) until the display shows the current bass setting.

For example:

SLS Bass +1.0

- Press ▲ or ▼ (remote or under the front panel) to change the bass.

The bass control allows you to adjust the bass response in the room by ± 5 dB in 0.5dB steps. Normally settings between +3.0 and -2.0 will give the most natural results.

To change the balance

- Press ◀ or ▶ (remote or under the front panel) until the display shows the current balance.

For example:

SLS Balance <0>

- Press ▲ or ▼ (remote or under the front panel) to move the listening position.

The display shows the direction and position of the listening position.

For example:

SLS Balance <3

The arrow indicates the direction, and the number indicates the position where 0 is central, 8 is in line with the corresponding main speaker, and 10 is fully to one side.

Changing the axis or phase

Larger models of the DSP loudspeakers have an axis control that allows you to compensate for the height of the listener relative to the tweeter.

You can also change the absolute phase of the signal, to compensate for signals which are out of phase, giving an unnatural-sounding bass.

The axis control is only available if your 818 is set up with fixed outputs.

To change the axis

- Press ◀ or ▶ (remote or under the front panel) until the display shows the current axis setting.

For example:

SLS Axis -1

- Press ▲ or ▼ (remote or under the front panel) to change the axis.

The axis can be adjusted between -2 and +3, where 0 corresponds to the axis of the treble unit. Usually a listener will be below that position, so we recommend settings of -1 or -2.

To change the phase

Either:

- Press ◀ or ▶ (remote or under the front panel) until the display shows the current phase.

For example:

SLS Phase +

- Press ▲ or ▼ (remote or under the front panel) to change the phase.

Or:

- Press **Function III** on the remote.

The display will show the new phase setting.

For example:

SLS Phase -

To store the tone settings

If you are using SpeakerLink loudspeakers or your 818 Reference Audio Core is set up for variable output you can store your preferred treble, bass, and axis settings in the 818.

- Press **Function Store** (remote).

The display shows:

Tones Stored

Adjusting the sensitivity of sources

This section explains how to use the input gain menu to set up the analogue sources connected to the 818.

To adjust the sensitivity of a source

To obtain the best signal-to-noise ratio for your analogue sources you can adjust the sensitivity of each input to give the highest level that does not produce clipping.

- Set **Input Gain Menu** to **Show**; see *Setup parameters*, page 35.
- Select the source you want to adjust, with loud source material playing.
- Press ◀ or ▶ (remote or under the front panel) until the display shows the current sensitivity.

For example:



Radio 2.0V In

- Press ▲ or ▼ (remote or under the front panel) to change the sensitivity.

You can select between sensitivities of 0.5V (most sensitive), 1.0V, 2.0V, or 2.5V (least sensitive).

If the sensitivity is set too high the input will clip the loudest passages. The display shows:

For example:



Radio 0.5V In Clip

In this case reduce the sensitivity.

If you have selected a digital source you cannot adjust the sensitivity. The display shows:

For example:



CD Not Analogue

Changing the front-panel display

The 818 Reference Audio Core displays information and settings on the 20-character front-panel display.

You can adjust the contrast and brightness of the front-panel display for optimum viewing, and choose what information is displayed.

To change the contrast or brightness

- Press ◀ or ▶ (remote or under the front panel), until the display shows the current contrast or brightness.

For example:



SLS Contrast 10

- Press ▲ or ▼ (remote or under the front panel), to change the selected setting.

You can change the contrast or brightness between 0 and 15.

To change the displayed information

- Press **Display** (remote or under the front panel).

Each time you press **Display** the display will step between the following options:

Display option	Example
Source and volume	SLS 65
Audio format	SLS PCM 44k
Blank	

If the 818 Reference Audio Core has detected an authentic MQA music stream the audio format display will indicate this, and show the original sample rate as encoded in the studio.

For example:



SLS MQA 384k

If the **Diagnostic displays** option has been selected, additional diagnostic displays are included; see *Setup parameters*, page 35.

Headphone mode

The 818 Reference Audio Core provides a headphone mode, which mutes the outputs to DSP loudspeakers. This allows you to connect a headphone amplifier, such as the Meridian Prime Headphone Amplifier, to the analogue outputs for headphone listening. For more information see *To connect to a Meridian Prime Headphone Amplifier*, page 31.

This option is only available if your 818 Reference Audio Core is set up with fixed outputs.

*If you want to mute the analogue outputs when not in use, set Relay Mute to Silent; see *To set the relay mute mode*, page 39. The relay mute acts normally when headphone mode is selected and returns to the silent mode when it is deselected.*

To select headphone mode

- Put the 818 into standby by pressing **Off** (front panel or remote).
- Press ◀ or ▶ (remote or under the front panel).

The display shows the current headphone mode setting:

For example:

Headphone Mode Off

- Press ▲ or ▼ (remote or under the front panel) to change the headphone mode setting.

For example:

Headphone Mode On

When you select a source the loudspeakers will be muted, and the display shows **Headphone Mode** in place of the volume.

For example:

CD Headphone Mode

Use the headphone amplifier to adjust the volume of the headphones.

Using the SpeakerLink controls

The 818 Reference Audio Core allows you to control several other settings supported by recent Meridian DSP loudspeakers

The controls described in this chapter are only available if your DSP loudspeakers are connected via SpeakerLink, the volume mode is **Fixed**, and **SpeakerLink** is set to **On** in the Setup menus; see *Setup parameters*, page 35.

The loudspeakers can be configured to ignore the SpeakerLink controls set via SpeakerLink, in which case these controls will have no effect.



Primary SpeakerLink controls

The **EBA** (Enhanced Bass Alignment) control improves the bass alignment in DSP loudspeakers that support it. Note that the extra processing adds a time delay, so it should be disabled for video sources.

The **Position** control adjusts the sound to compensate for the placement of the main loudspeakers, such as near a wall or corner.

The **EBC** (Enhanced Boundary Compensation) control adjusts the sound to compensate for the height of the ceiling.

The **Loudness** control alters the frequency response to make music sound more natural when played at a low volume setting.

Each of these controls is only available if the corresponding option **EBA Menu**, **Position Menu**, **EBC Menus**, or **Loudness Menu** is set to **Show** in the setup menus; see *Setup parameters*, page 35.

To specify Enhanced Bass Alignment

- Press ◀ or ▶ (remote or under the front panel) until the display shows the current EBA setting.

For example:



SLS EBA On

- Press ▲ or ▼ (remote or under the front panel) to choose between **On** or **Off**.

To specify the main speaker position

- Press ◀ or ▶ (remote or under the front panel) until the display shows the current location setting.

For example:



SLS Position Corn.

Press ▲ or ▼ (remote or under the front panel) to choose between **Corn.** (corner), **Shelf**, **Wall**, or **Free** (free standing).

To specify Enhanced Boundary Control

- Press ◀ or ▶ (remote or under the front panel) until the display shows the current EBC setting.

For example:



SLS EBC Max

- Press ▲ or ▼ (remote or under the front panel) to specify how reflective the room surfaces are. Choose between **Off** (unreflective), **Min**, **Med**, or **Max** (highly reflective).

To change the loudness

- Press ◀ or ▶ (remote or under the front panel) until the display shows the current loudness setting.
- Press ▲ or ▼ (remote or under the front panel) to turn the loudness control on or off.

For example:



SLS Loudness On

Subwoofer setup controls

If you have one or more subwoofers connected to your 818 Reference Audio Core via SpeakerLink, the following controls allow you to adjust the relationship between the subwoofers and main speakers.

The **Mode** control changes the distribution of bass between the main speakers and the subwoofer to suit different types of material.

The **Sub Filter** control adjusts the subwoofer crossover frequency.

The **Sub Gain** control adjusts the subwoofer gain.

The subwoofer controls are only available if **Subwoofer Menus** is set to **Show** in the setup menus; see *Setup parameters*, page 35.

To select Music Mode or Movie Mode

- Press ◀ or ▶ (remote or under the front panel) until the display shows the current mode.

For example:



SLS Music Mode

- Press ▲ or ▼ (remote or under the front panel) to select between Music Mode, recommended for classical music, and Movie Mode, recommended for movie soundtracks.

To change the subwoofer filter

- Press ◀ or ▶ (remote or under the front panel) until the display shows the current subwoofer filter mode.

For example:



SLS Subwoofer 1

- Press ▲ or ▼ (remote or under the front panel) to select between: **Off** (subwoofer off), **1** (80Hz crossover), or **2** (120Hz crossover).

To change the subwoofer gain

- Press ◀ or ▶ (remote or under the front panel) until the display shows the current subwoofer gain.

For example:



SLS Sub. Gain 0

- Press ▲ or ▼ (remote or under the front panel) to adjust the relative subwoofer gain between **-15**, **0** (the normal setting), and **+15** in 1dB steps.

Installing the 818 Reference Audio Core

This chapter explains how to install the 818 Reference Audio Core. It describes what you should find when you unpack the product, and how you should connect it to the other equipment in the system.

You should not make any connections to the product or to any other component in the system while the AC power supply is connected and switched on.



Unpacking

The 818 Reference Audio Core is supplied with the following accessories:

- MSR+ remote control with batteries, manual, and spare key caps.
- Meridian Comms lead.
- Power cord.
- This manual.

If any of these items are missing please contact your retailer.

NOTE: You should retain the packaging in case you need to transport the unit.

Back panel

The following diagram gives details of the back panel connections:

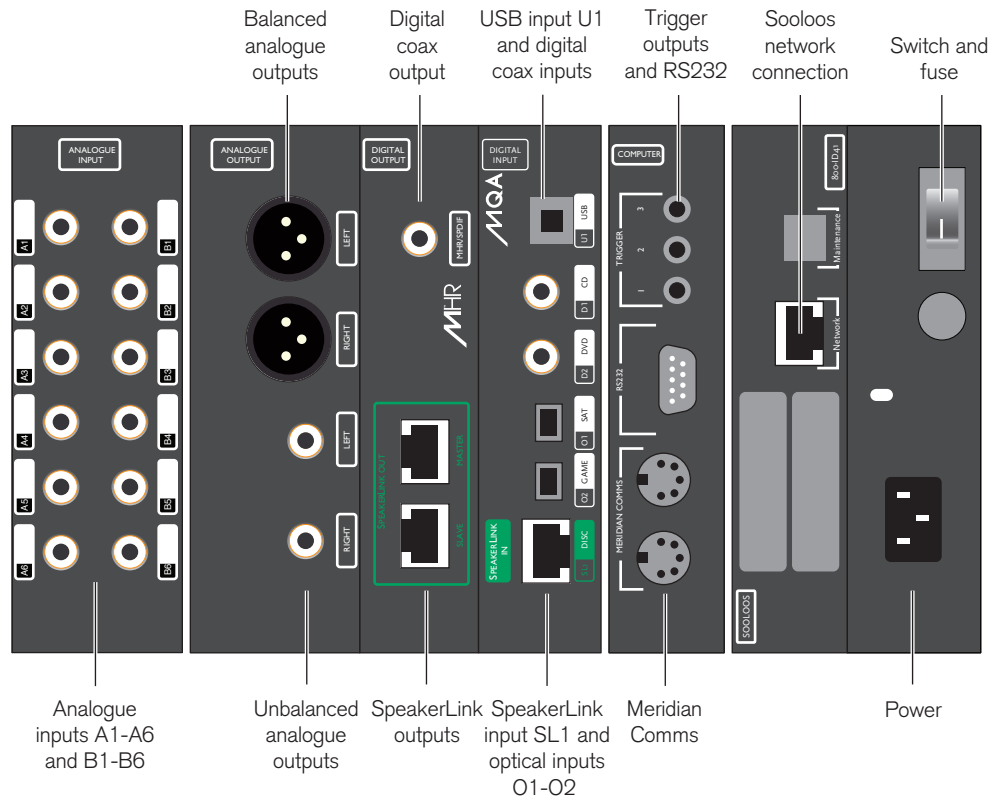

Audio outputs

Use this output	To connect to this
BALANCED OUT	The balanced analogue inputs of a preamplifier, or a power amplifier such as the G57, using XLR leads.
ANALOGUE OUT	The unbalanced analogue inputs of a preamplifier, or a power amplifier such as the G57, using analogue phono leads.
DIGITAL OUT	The digital input of a surround processor, such as the 861 Reference Digital Surround Controller, or DSP loudspeakers, using a 75Ω digital cable.
MERIDIAN SPEAKERLINK	DSP Loudspeakers with Meridian SpeakerLink connectors, using SpeakerLink leads. Use the upper socket for the Master speaker.

Audio inputs

Use this input	To connect to this
ANALOGUE IN A1+A2 (Radio), A3+A4 (TV), A5+A6 (Cable), B1+B2 (Tape), B3+B4 (PVR), B5+B6*	The analogue outputs of a source, such as a TV or tape deck.
DIGITAL INPUT D1 (CD), D2 (DVD)	The digital output of a source such as a DVD player.
SPEAKERLINK INPUT SL1 (Disc)	The SpeakerLink output of a Meridian source, using a Meridian SpeakerLink lead.

* In each case the odd-numbered input is the left channel and the even-numbered is the right channel.

Audio inputs (continued)

Use this input	To connect to this
OPTICAL INPUT O1 (Sat), O2 (Game)	The optical output of a source such as a satellite receiver.
USB INPUT U1 (USB)	A personal computer USB socket.
NETWORK (SLS)	A Meridian Sooloos Digital Media System.

The default assignment of the source to each input is shown in brackets after the input name in the above table.

Communications connections

Use this connection	To connect to this
MERIDIAN COMMS	Other Meridian equipment, or Meridian DSP loudspeakers.
RS232 connection	A computer, for configuring the 818, or a serial control system.
TRIGGER OUTPUT 1, 2, 3	Equipment to be triggered by a 12V 100mA signal.

Applications

To connect to a digital source (eg DVD player)

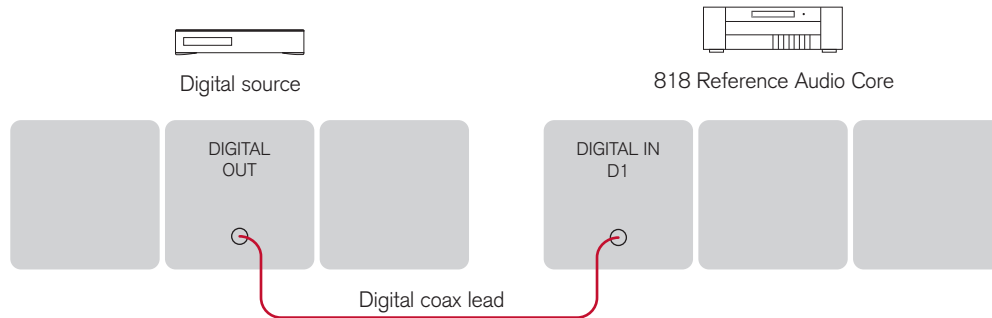

You can connect up to two digital coax inputs and two digital optical inputs to the 818 Reference Audio Core.

- Connect the digital source to an appropriate digital input socket on the 818, using either screened coax phono leads, or a Toslink lead.

To connect to an analogue source (eg TV tuner)

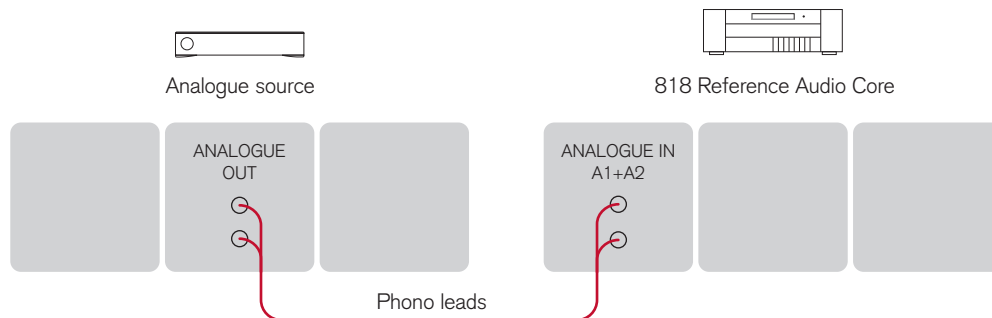

You can connect up to six analogue sources to the 818 Reference Audio Core

- Connect the analogue source to one of the analogue input sockets of the 818, using screened coax phono leads.

To connect to a computer via USB

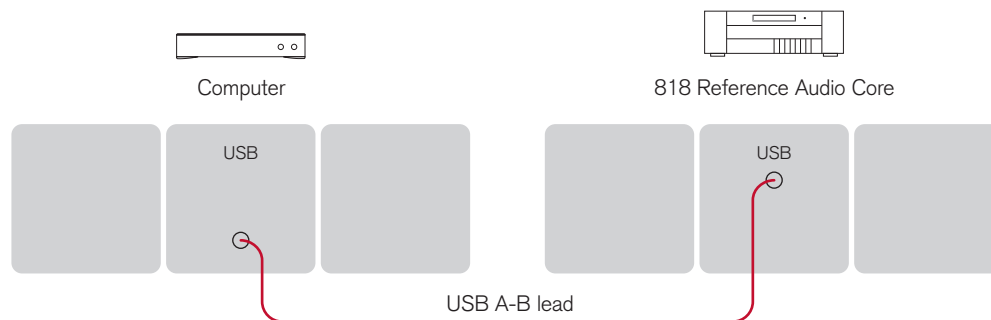

You can connect the 818 Reference Audio Core to a PC or Mac USB socket to allow you to use the 818 as a digital audio output device.

On a PC, Windows XP/SP2 or later is required. Note that you must install the drivers (available from your Meridian dealer or www.meridian-audio.com) before you connect the product to a Windows PC.

On a Mac, OS X 10.4 or later is recommended. Appropriate drivers will be installed automatically when you connect for the first time.

Linux computers that support USB Audio Class 2.0 drivers can also be used.

When the 818 is plugged in to the computer it will appear as a sound output device called **Meridian 800 Series Output** in the **Sound** control panel (PC) or **Sound** System Preferences panel (Mac).

The source will be labelled USB, unless it has been given a custom label.

Note: The computer volume control will continue to work as expected, but for highest quality you should set it to maximum and use the Meridian volume control in the 818 instead.

To connect to DSP loudspeakers using SpeakerLink (daisy chain)

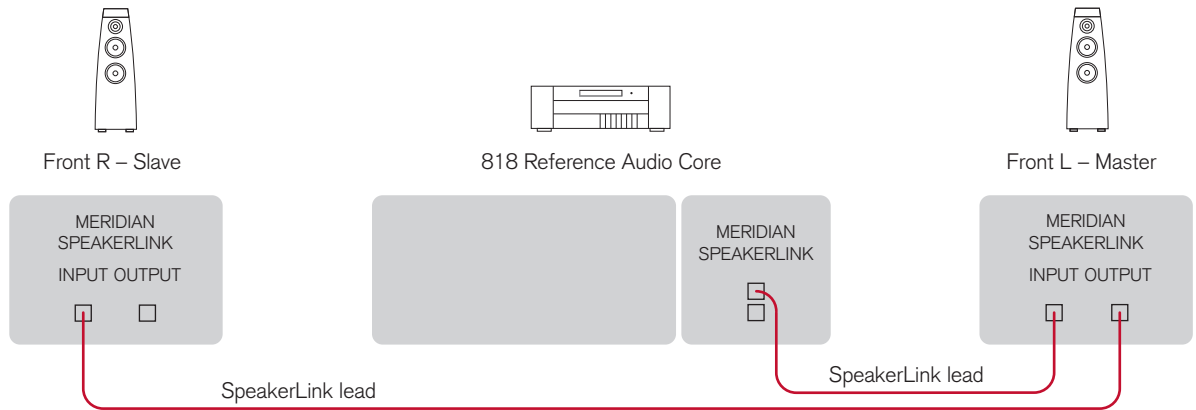

The 818 can be connected directly to Meridian DSP loudspeakers to create a complete stereo system, with volume and other preamplifier controls provided by the loudspeakers via the MSR+ or the front panel.

The Meridian SpeakerLink connection provides both two-channel digital audio and Meridian Comms control.

This is an alternative to the “home run” wiring configuration shown in the next section.

- Connect the upper SpeakerLink output from the 818 to the SpeakerLink input on the DSP loudspeaker chosen as the Master, using a SpeakerLink lead.
- Connect the SpeakerLink output from the Master DSP loudspeaker to the SpeakerLink input on the other (Slave) DSP loudspeaker, using a second SpeakerLink lead.
- Configure the loudspeakers as described in the *Meridian DSP Loudspeaker User Guide*.

- Configure the 818 as described in *Configuring the 818 Reference Audio Core*, page 33, or by using the Meridian Configuration Application; see *Installing the Meridian Configuration Application*, page 40.

To connect to DSP loudspeakers using SpeakerLink (home run)

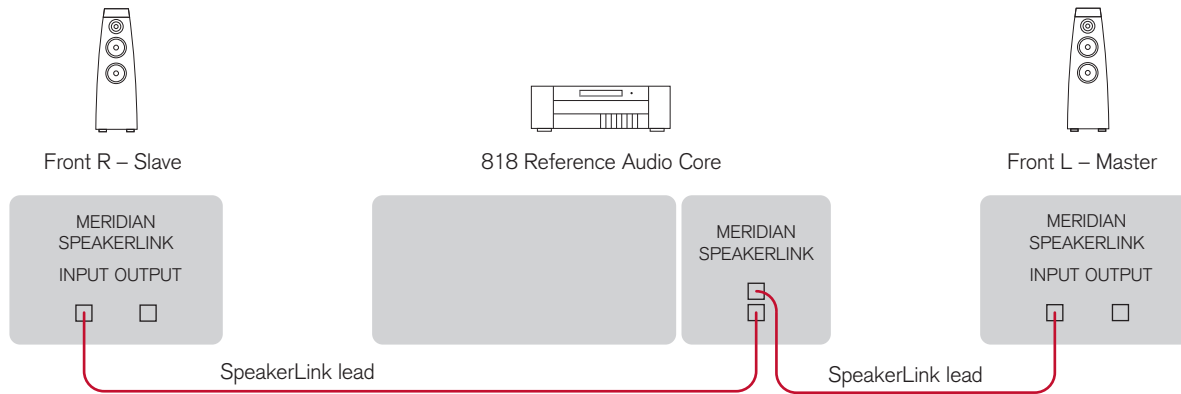

The 818 can be connected directly to Meridian DSP loudspeakers to create a complete stereo system, with volume and other preamplifier controls provided by the loudspeakers via the MSR+ or the front panel.

The Meridian SpeakerLink connection provides both two-channel digital audio and Meridian Comms control.

This is an alternative to the “daisy chain” wiring configuration shown in the previous section.

- Connect the upper SpeakerLink output from the 818 to the SpeakerLink input on the DSP loudspeaker chosen as the Master, using a SpeakerLink lead.
- Connect the lower SpeakerLink output from the 818 to the SpeakerLink input on the other (Slave) DSP loudspeaker, using a second SpeakerLink lead.
- Configure the loudspeakers as described in the *Meridian DSP Loudspeaker User Guide*.

- Configure the 818 as described in *Configuring the 818 Reference Audio Core*, page 33, or by using the Meridian Configuration Application; see *Installing the Meridian Configuration Application*, page 40.

To connect to DSP loudspeakers using the digital and Comms connections

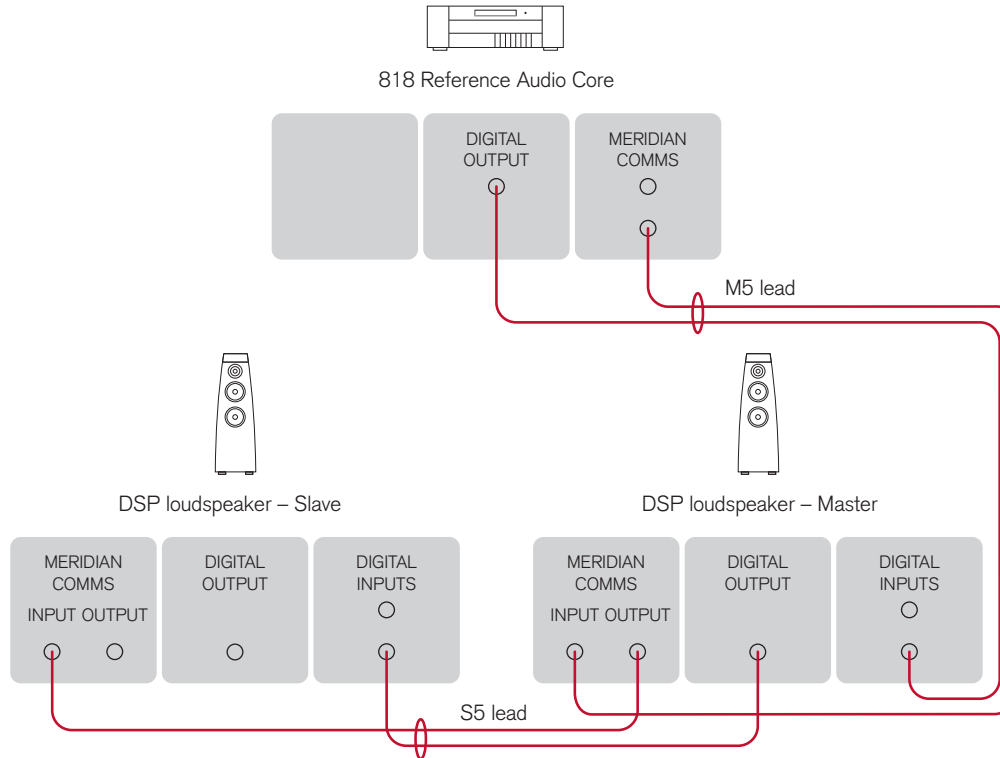

If your DSP loudspeakers do not provide Meridian SpeakerLink connections you can connect to them using the Digital and Meridian Comms connections.

- Connect the DIGITAL OUTPUT and a COMMS socket from the 818 to DIGITAL INPUT 1 and the COMMS input on the DSP loudspeaker chosen as the Master, using an M5 lead.
- Connect the DIGITAL and COMMS outputs from the Master DSP loudspeaker to DIGITAL INPUT 1 and the COMMS input on the other (Slave) DSP loudspeaker, using an S5 lead.

- Configure the loudspeakers as described in the *Meridian DSP Loudspeaker User Guide*.
- Configure the 818 as described in *Configuring the 818 Reference Audio Core*, page 33, or by using the Meridian Configuration Application; see *Installing the Meridian Configuration Application*, page 40.

To connect to a power amplifier

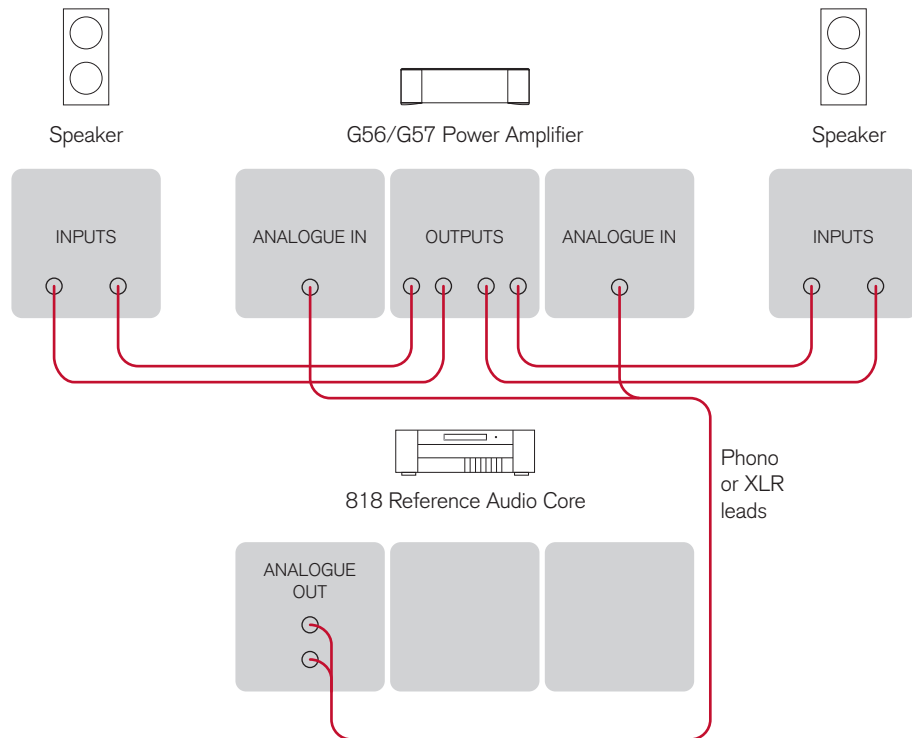

The 818 analogue outputs allow you to connect to a pair of analogue active loudspeakers, or to analogue passive loudspeakers via a power amplifier.

- Connect the balanced or unbalanced ANALOGUE OUTPUT connections from the 818 to the inputs of the analogue active loudspeakers or power amplifier.
- Configure the 818 as described in *Configuring the 818 Reference Audio Core*, page 33, or by using the Meridian Configuration Application; see *Installing the Meridian Configuration Application*, page 40.

To connect to an 861 Reference Digital Surround Controller

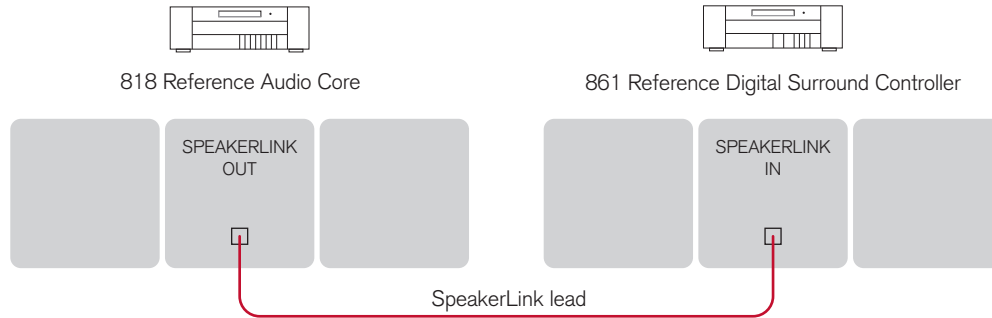

You can use the 818's SpeakerLink outputs to connect to other Meridian products, such as the 861 Reference Surround Controller.

- Connect the SpeakerLink output from the 818 to the SpeakerLink input on the 861, using a SpeakerLink lead.
- Configure the 818 as described in *Configuring the 818 Reference Audio Core*, page 33, or by using the Meridian Configuration Application; see *Installing the Meridian Configuration Application*, page 40.
- Configure the 861 using the Meridian Configuration Application so that all sources connected to the 818 are received by the 861 on the SpeakerLink connection.

To connect to a Meridian Prime Headphone Amplifier

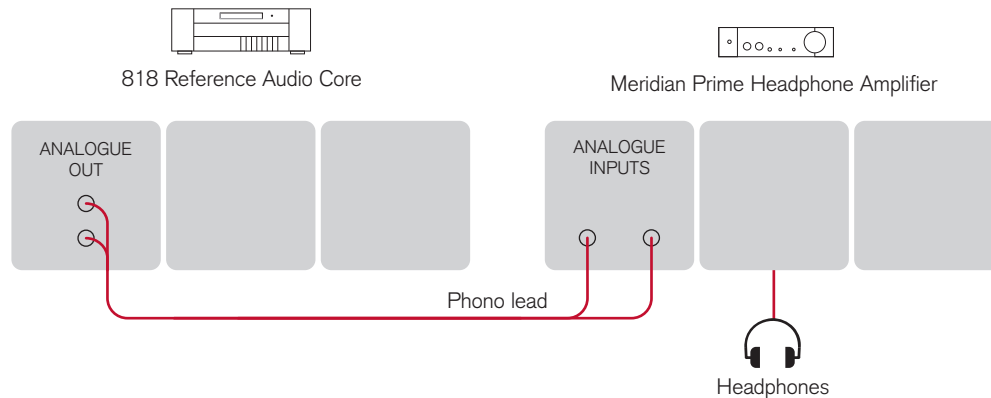

If your system uses DSP loudspeakers, you can use the analogue outputs from the 818 Reference Audio Core to connect to a headphone amplifier, such as the Meridian Prime Headphone Amplifier.

- Connect the Unbalanced Analogue output from the 818 to the Analogue Input on the Meridian prime Headphone Amplifier, using phono leads.
- Select **Headphone Mode** to mute the sound through the loudspeakers; see *Headphone Mode*, page 15.
- Use the volume control on the Meridian Prime Headphone Amplifier to adjust the level for the headphones.

To connect to other Meridian G Series or 800 Series equipment

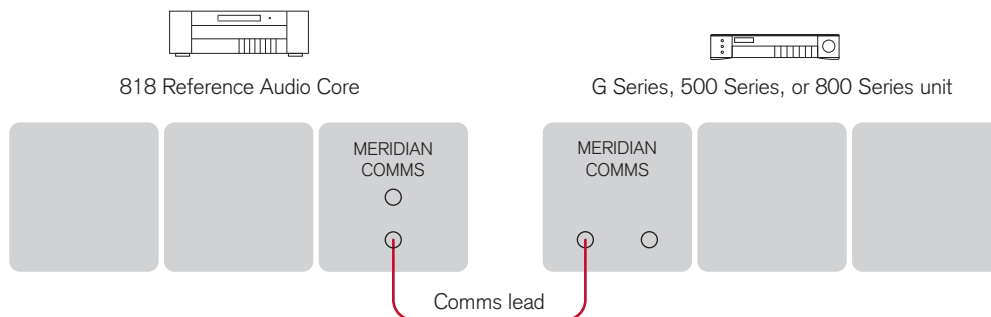

In a system of Meridian products, one of the products acts as the controller for the system, receiving infra-red commands from the MSR+ and then, if appropriate, relaying them to the other products via the Comms link.

The following automatic setup procedure should be used to set up the Comms correctly between several products:

- Connect one of the DIN COMMS sockets on the back panel of the 818 to one of the COMMS sockets on another G Series, 500 Series, or 800 Series unit, using the Comms leads provided with the products.

The sequence in which you connect the units is not important.

- Switch all the units to standby.
- Press **Clear** (remote).

Each unit will display: **Auto**

One unit will then be designated as the controller.

The display shows: **Controller**

All the other units will be configured as non-controllers.

The displays show: **Not Con.**

If for any reason the automatic setup does not work, make sure you are operating the remote from a position where all the units can receive the infra-red, and try again.

If this fails:

- Restore the default operation by selecting one of the standard types; see *Choosing a standard setting*, page 34.

Do not, under any circumstances, connect any equipment other than Meridian G Series or 800 Series to any socket marked COMMS on the back of the product.

Configuring the 818 Reference Audio Core

This chapter explains how to set up the 818 Reference Audio Core for most standard configurations of your other equipment, using just the front-panel controls and MSR+.

For complete control over all aspects of the 818's configuration it is recommended that you use the Meridian Configuration Program; for more information see *Installing the Meridian Configuration Application*, page 40.



Choosing a standard setting

The 818 provides two standard settings, called Types, which configure all aspects of the 818 into standard configurations.

These standard Types are shown in the following table:

Type	Label	Description
1	Fixed	Fixed output, for use with Meridian DSP loudspeakers.
2	Variable	Variable output, for use with power amplifiers and analogue speakers.

In addition, your installer may have provided one or more named User Types, with settings appropriate to the configuration of equipment when your 818 was installed.

You can reset the configuration of the 818 to any of these Types to restore it to the state it was in when it was installed. **Note:** Selecting a Type will clear any configuration changes you have made.

To select a standard setting

Warning: this procedure will reset any configuration changes you have made.

- Switch off any power amplifiers that are connected to the 818 and put any digital speakers into standby.
- Put the 818 into standby by pressing **Off** (front panel or remote).
- Press and hold down **Volume +** (under the front panel).

The display shows:

Type in... 3

- Keep holding down **Volume +** for a further three seconds.

The display shows:

Type- please wait.

Then after a short delay the display shows the current Type.

For example:

Type 1 Fixed

- Press **▲** or **▼** on the front panel (or **Volume +** or **Volume -** under the front panel) to change the Type number.

The display shows:

Typing, please wait.

Either:

- Press **Setup** (under the front panel) to skip directly to front panel setup mode; see *Setup parameters*, page 35.

Or:

- Wait for one second, and then put the 818 into standby by pressing **Off** (front panel or remote).
- Switch on again to use the standard settings you have selected.

Setup parameters

To enter front panel setup mode

- Put the 818 into standby by pressing **Off** (front panel or remote).
- Press and hold down **Setup** (under the front panel).

The display shows:

Setup in... 3

- Keep holding down **Setup** for a further three seconds.

When the countdown finishes the display will show the first of the setup menus.

For example:

IR Auto

To use the setup menus

- Press ◀ or ▶ (under the front panel) until the display shows the parameter you want to change.

For example:

Output Fixed

- Press ▲ or ▼ (under the front panel) to change the parameter.

The following table gives a list of all the Setup parameters:

Parameter	Range	Default	Notes
IR	Auto, Controller, Not Controller	Auto	See <i>To connect to other G Series or 800 Series equipment</i> , page 32.
Startup Volume	LV or 25 to 87	Last Valid	See <i>To set the startup volume</i> , page 36.
Output	Fixed, Variable		See <i>To set the output mode</i> , page 37.
SpeakerLink	Off, On	On	See <i>To set the SpeakerLink mode</i> , page 37.
EBA Menu *	Show, Hide	Show	Enables the EBA menu; see <i>Primary SpeakerLink controls</i> , page 18.
Position Menu *	Show, Hide	Hide	Enables the position menu; see <i>Primary SpeakerLink controls</i> , page 18.
EBC Menus *	Show, Hide	Hide	Enables the EBC menus; see <i>Primary SpeakerLink controls</i> , page 18.
Measurement *	Inches, Metric	Inches	See <i>To set the measurement units</i> , page 38.
Room Height *	58-158 inches, 150-400cm	58inches (150cm)	See <i>To specify the room height</i> , page 38.
Subwoofer Menu *	Show, Hide	Hide	Enables the subwoofer menus; see <i>Subwoofer setup controls</i> , page 19.
Loudness Menu *	Show, Hide	Hide	Enables the Loudness menu; see <i>Primary SpeakerLink controls</i> , page 18.
Relay Mute	Normal, Silent	Normal	See <i>To set the relay mute mode</i> , page 39.
Input Gain Menu	Show, Hide	Hide	Enables the input gain menu; see <i>Adjusting the sensitivity of sources</i> , page 13.
Diagnostics	Show, Hide	Hide	To help diagnose technical issues.

* These options are only available if **Output** is **Fixed** and **SpeakerLink** is **On**.

Setting the startup volume

When you switch the 818 from standby you can choose to set the volume to a fixed value, or to the last value it was set to.

To set the startup volume

- Press ◀ or ▶ (under the front panel) until the display shows the startup volume setting.

For example:



- Press ▲ or ▼ (under the front panel) to change the parameter.

You can set it to any value between 25 and 87, or LV (Last Valid) which restores the volume to the last value it was set to.

For example:



Setting the output mode and SpeakerLink setting

The output mode determines whether the 818 provides the volume control for the analogue outputs.

The SpeakerLink setting is only available if **Output Mode** is set to **Fixed**, and determines whether the loudspeaker settings are sent to DSP loudspeakers connected via the SpeakerLink connection.

If **SpeakerLink** is set to **On**, the volume, bass, treble, axis, and balance are sent to the speaker via SpeakerLink; otherwise they are sent via the Comms connection.

In addition, if **SpeakerLink** is set to **On** additional EBA, position, EBC, subwoofer, and loudness controls are available, and will control those features in DSP loudspeakers that support them.

The following table shows which settings you should choose for different applications:

818 application	Output	SpeakerLink
Connected to recent DSP loudspeakers via SpeakerLink.	Fixed	On
Connected to digital loudspeakers that do not support SpeakerLink, or a Digital Surround Processor.	Fixed	Off
Connected to an analogue preamplifier or integrated amplifier.	Fixed	Off
Connected directly to a power amplifier.	Variable	Off

To set the output mode

- Press ◀ or ▶ (under the front panel) until the display shows the current output setting.

For example:

- Press ▲ or ▼ (under the front panel) to change the setting.

For example:

To set the SpeakerLink mode

- Press ◀ or ▶ (under the front panel) until the display shows the current SpeakerLink setting.

For example:

- Press ▲ or ▼ (under the front panel) to change the setting.

For example:

Configuring the EBC settings

The EBC control uses information about the room dimensions to compensate for reflections from the walls and ceiling. These menus are only available when **EBC Menus** is set to **Show**.

To set the measurement units

- Press ◀ or ▶ (under the front panel) until the display shows the current measurement setting.

For example:

A rectangular LCD display showing the text "Measurement Metric" in a monospaced font.

- Press ▲ or ▼ (under the front panel) to change the setting.

For example:

A rectangular LCD display showing the text "Measurement Inches" in a monospaced font.

To specify the room height

- Press ◀ or ▶ (under the front panel) until the display shows the current room height setting.

For example:

A rectangular LCD display showing the text "Room Height 150cm" in a monospaced font.

- Press ▲ or ▼ (under the front panel) to change the setting.

For example:

A rectangular LCD display showing the text "Room Height 200cm" in a monospaced font.

The room height setting can be varied between 150 cm (58in) and 400cm (158in) in steps of 5cm (2in). If your room height is outside this range set the nearest available value.

Muting the analogue relay

The 818 Reference Audio Core includes relay control of the analogue outputs, to ensure a totally silent output. The relay is activated when you mute the sound, and to avoid clicks in the loudspeakers when changing source.

If **Output Mode** is set to **Fixed** and you are using DSP loudspeakers you can choose to disable the muting relay, which permanently mutes the analogue outputs.

To set the relay mute mode

- Press ◀ or ▶ (under the front panel) until the display shows the current relay mute setting.

For example:

A monochrome LCD display showing the text "Relay Mute" on the left and "Normal" on the right.

- Press ▲ or ▼ (under the front panel) to change the setting.

For example:

A monochrome LCD display showing the text "Relay Mute" on the left and "Silent" on the right.

Installing the Meridian Configuration Application

The Meridian Configuration Application is not included with this product.

The application should be installed from the Internet.

Requirements

To use the Meridian Configuration Application you need:

- A computer running Windows 95, 98, 2000, NT 4, ME, XP, Vista, Windows 7, or Windows 8.
- 10Mbytes of free disk space.
- A 9-pin serial port or suitable serial adaptor (such as USB-Serial, PC Card, etc).
- An RS232 null-modem cable.
- A mouse or similar pointing device – the application cannot be operated solely from the keyboard.

The Meridian Configuration Application communicates with the products you are setting up via a serial cable.

You can connect the product to a 9-pin serial port on the computer.

Alternatively, a USB-to-serial converter, available from most computer retailers, can be used to connect between the product and a USB port on the computer.

Installation

To install the application you will need a computer that is connected to the Internet.

- Type the following URL into the address bar of a Web browser:

www.meridian-audio.com/download/setup.exe

If you are asked whether to Run or Save the application:

- Click **Run**.

Otherwise:

- Run the setup.exe application once it has downloaded.

The **Setup** application's **Welcome** page will be displayed.

- Follow the instructions.

On the **Preferences** page:

- Leave **Install for all users** selected, unless you want to restrict use of the application to yourself on a multi-user machine.

User guide

You can download an electronic copy of the *Meridian Configuration Program Guide* in Acrobat format from our website:

www.meridian-audio.com

Follow the links to the 818 support section where you will find this and other useful documentation.

Index

A

accessories 22
 analogue inputs 23
 analogue outputs 23
 analogue source, connecting to 24
 auxiliary output 22
 axis, changing 12

B

back panel connections 22
 balance, changing 11
 balanced outputs 23
 bass, changing 11
 brightness, front-panel display 14

C

clip indicator 13
 Comms, connecting 23, 28, 32
 communications connections 23
 computer, connecting to 25
 configuring 33
 connecting
 to a computer 25
 to a digital source 24
 to an 861 Reference Digital Surround Controller 30
 to an analogue source 24
 to a power amplifier 29
 to DSP loudspeakers 26, 27, 28
 to Meridian equipment 32
 contrast, front-panel display 14

D

digital inputs 23
 digital output 23
 digital source, connecting to 24
 Digital Surround Controller,
 connecting to 30
 display, front panel 14
 DSP loudspeakers, connecting to
 26, 27, 28

E

EBA control 18
 EBC control 18
 EBC settings, setting 38
 Enhanced Bass Alignment, specifying
 18
 Enhanced Boundary Control,
 specifying 18

F

front panel keys 6

G

gain menu 13

H

Headphone mode 15
 headphone mode 15
 headphones, connecting 31

I

input gain menu 13
 inputs 23
 analogue 23
 digital 23
 network 23
 optical 23
 SpeakerLink 23
 USB 23

L

loudness, changing 18
 loudspeaker setup controls
 Enhanced Bass Alignment 18
 Enhanced Boundary Control 18
 speaker location 18
 subwoofer crossover 19
 subwoofer gain 19

M

measurement units, setting 38
 Meridian Configuration Application
 40
 Meridian DSP loudspeakers,
 connecting to 26, 27, 28
 Meridian Prime Headphone Amplifier,
 connecting to 31
 Meridian System Remote keys 7
 Movie Mode, selecting 19
 MQA 2, 14
 Music Mode, selecting 19
 muting the analogue relay 39
 muting the sound 10

N

network input 23

O

optical inputs 23

output mode, specifying 37

outputs 23

 analogue 23

 balanced 23

 digital 23

 SpeakerLink 23

P

phase, changing 12

Position control 18

power amplifier, connecting to 29

R

registration iv

Relay Mute mode 15

relay mute mode 39

room height, specifying 38

RS232 connection 23

S

safety warnings ii

setup mode 35

Setup parameters 35

Sooloos, using 9

Sooloos input 23

sound, muting 10

sources 9

 adjusting sensitivity 13

 selecting 9

SpeakerLink

 connecting with 26, 27

 inputs 23

 outputs 23

SpeakerLink mode, setting 37

speaker location, specifying 18

specifications 4

standard settings, selecting 34

standby

 switching on from 8

 switching to 8

startup volume 10

startup volume, setting 36

subwoofer controls 19

 Movie Mode 19

 Music Mode 19

 subwoofer filter 19

 subwoofer gain 19

switching on and off 8

T

tone settings, storing 12

treble, changing 11

trigger outputs 23

Types 34

U

unpacking 22

USB, connecting 25

USB input 23

V

volume, adjusting 10