

ESOTERIC

Super Audio CD/CD Player **K-05XD**



The Ultimate Five

The Ultimate Five

Uncompromising quality refined with flagship technology.
Beautiful styling. High-quality sound worthy of the term "high-end".

The core model of Esoteric Super Audio CD players, the K-05, is finally available in an XD edition. The design platform is completely revamped and now features VRDS-ATLAS and Master Sound Discrete DAC / Clock circuitry. This is an arrival of a completely new Super Audio CD player.

The first K-05 model was introduced in 2011, evolved into the K-05X in 2015, and K-05Xs in 2018. It has become the best-selling model at the heart of the Esoteric K Series. The K-05XD inherits the philosophy of the historic K-05 series but is totally redesigned as a Super Audio CD player; completely different from the previous 05 models by way of revamping it with an all-new design platform.



A wide variety of tones that expressively portray the details of music has been achieved, while acquiring the flexibility to adapt to a truly diverse range of genres from silky smooth arias to edgy rock.

The lineage of the legendary models fascinating music lovers, and blissful sound brought by an encounter with new technology, the K-05XD invites you to enjoy it to the fullest.

A new VRDS-ATLAS transport mechanism “ATLAS 05” is designed exclusively for this model, and the DAC section employs a discrete circuit with the “Master Sound Discrete DAC” to further refine the music reproduction capability.

Incorporating the fruits of our labor resulting from the development of the Grandioso G1X master clock generator, a unique discrete clock circuit for built-in players, the “Master Sound Discrete Clock for Digital Player” is employed.

An enlarged double-layer chassis accommodates the upgraded ATLAS mechanism, each larger circuit block, and the power supply section, while it’s the elegant appearance of the K-05XD, – which is even closer now to the upper models, – subtly asserts the richness of its content, worthy of being called a major innovation.





VRDS ATLAS

VRDS (Vibration-Free Rigid Disc-Clamping System) is the core technology of the CD/Super Audio CD transport mechanism that Esoteric has been focusing on since the establishment of the brand. The disc is securely clamped to a turntable of the same diameter for rotation, thoroughly eliminating unwanted vibrations from the disc itself and the mechanism. Servo current is minimized by correcting disc warpage with the turntable and greatly improving the relative optical axis accuracy between the optical pickup and the disc pit surface. With these features, disc read errors are significantly reduced and achieves superior sound quality.

New VRDS-ATLAS “ATLAS 05”

The VRDS mechanism continues to evolve. The biggest highlight in its illustrious history is the new VRDS-ATLAS platform, which boasts the highest level of perfection and sound quality. The K-05XD edition is equipped with the newly designed VRDS-ATLAS “ATLAS 05”. The ATLAS 05 is based on the same design architecture of the “VRDS-Reference” mechanism employed in Grandioso models, but exclusively customized for the K-05XD.



ATLAS 05 – Mechanical construction

The core of the ATLAS 05 transport mechanism is a hybrid turntable made of high-precision aluminum and polycarbonate materials. This beautiful design, inspired by a master tape reel, and its superior vibration control capability, embody the identity of the 05 Series Super Audio CD Players, which have a history of

dating back more than 15 years, to the birth of the P-05. Polycarbonate, the same material as the disc, contributes to natural sound quality with little coloration, and the hybridization with spoke-shaped aluminum effectively disperses vibration modes associated with high-speed rotation, successfully minimizing rotation noise and rotation inertia, while the bridge section supporting the turntable is larger and wider than that of the VRDS-NEO, and is made of a machined aluminum block 10 mm thick with a beautiful hairline finish, while its high rigidity and heavy weight construction effectively eliminate vibrations that affect sound quality.

Wide and low center of gravity design

Key to the VRDS-ATLAS design concept is mechanical grounding technology, which dampens vibrations more efficiently. The entire mechanism is designed with a wide and low profile design to achieve a low center of gravity. At the same time, by mounting the turntable drive motor on the underside of the turntable, the path for vibration to be grounded is greatly shortened and mechanical noise is reduced. The tray is minimally hollowed out to increase rigidity, and a rubber stopper prevents resonance when the tray is stored.

Chassis Construction and Component Layout

With the complete renewal of the 05 series, the chassis has undergone the most significant evolution in terms of appearance. To accommodate a larger ATLAS mechanism than the VRDS-NEO

and to further enhance the scale of the circuitry, a dual layer large chassis is employed instead of the previous slim, single-layer chassis, while maintaining the same depth. The VRDS-ATLAS transport mechanism is center-placed and rigidly fixed to a 5mm-thick steel bottom chassis via a 2mm-thick steel base plate, while the entire chassis is then supported at three points by a unique pin-point foot (Japan Patent No. 4075477 and 3778108). Like upper class models, the bottom chassis has been laser cut with slits to effectively disperse and suppress vibrations from the rotating mechanism. Inside the dual layer chassis, audio circuit boards are mainly placed on the upper layer and power supply circuits and transformers on the lower layer to prevent magnetic flux leakage and vibration, and to minimize power supply wiring to refine the pure tone quality.



Semi-floating top panel

The semi-floating structure of the top panel, which is not tightened with screws, brings out extensive and open sound.

Master Sound Discrete DAC

By assembling circuits with discrete components that have been carefully examined, we aim to perfectly reproduce the “vibrancy” and “energy” of music, which cannot be achieved with integrated chips. The pride of Esoteric’s top engineering team has been put to the test in the Master Sound Discrete DAC, a discrete D/A converter designed completely in-house.

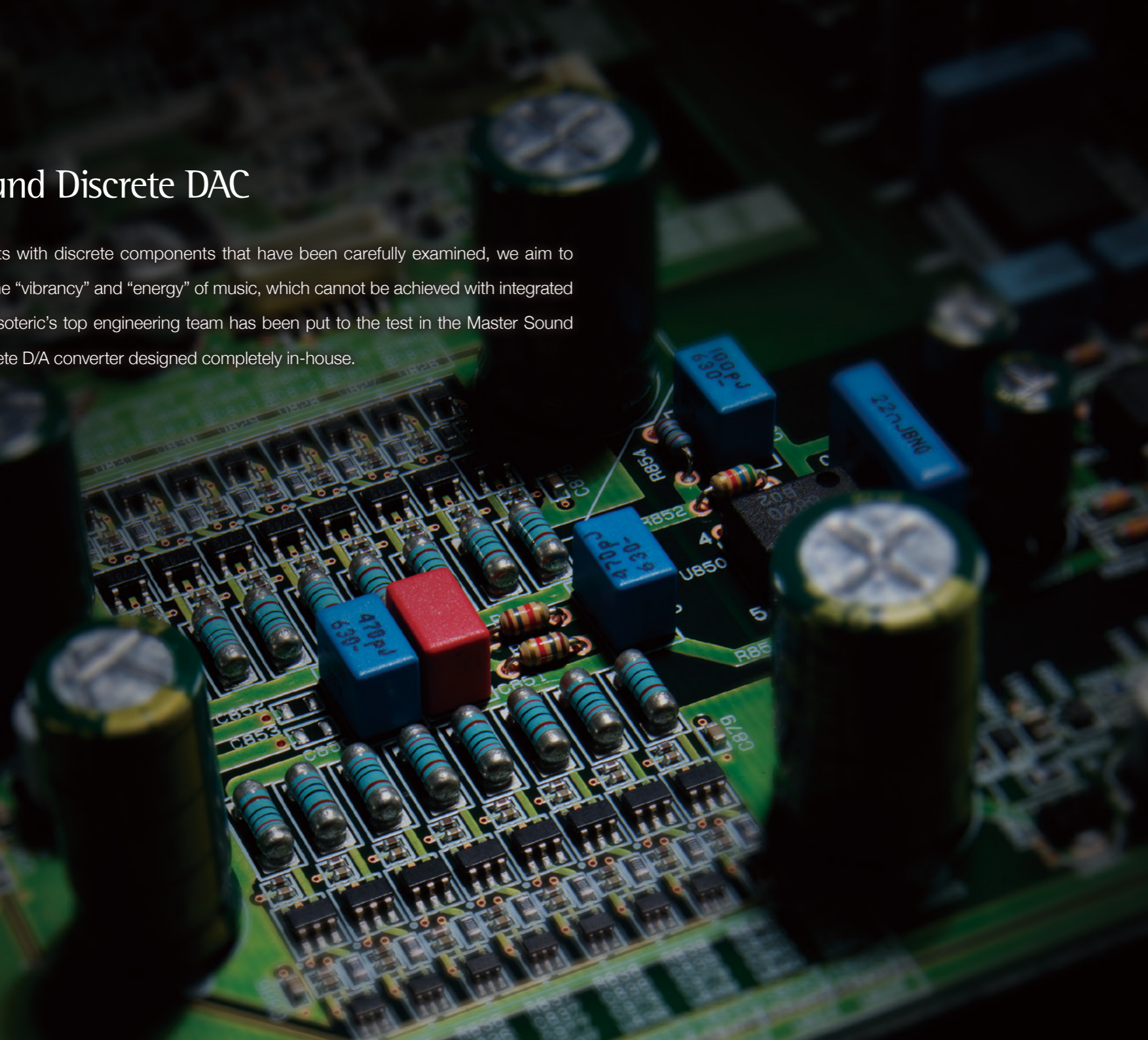

Luxurious material input and massive current output capability

The Master Sound Discrete DAC was first installed in the Grandioso D1X and was highly acclaimed for its live sound. On the K-05XD, it condenses the essence of the Grandioso K1X version, but with a simplified circuit configuration that takes the 05 series to a new horizon. The DAC consists of 16 elements per channel, and each element consists of components such as clock drivers, logic circuits, capacitors, and resistors, while each key component is independent of each other, and the luxurious configuration is a direct extension of the philosophy of the high-end models, so that all the energy of the music is output in its purest form.

High performance digital processing

Employing a proprietary Delta-Sigma modulator supporting 64bit/512Fs, the K-05XD supports the latest formats including DSD 22.5MHz playback. The FPGA digital processing algorithms for optimal playback of DSD and PCM, respectively, are dedicated algorithms developed for the Master Sound Discrete DAC.

Sound quality corroborated by advanced quality control

In discrete DACs, where component tolerances directly affect calculation accuracy, a high level of expertise and quality control is required in the manufacturing of electronic boards. Esoteric’s own factory boasts world-class board mounting technology, including soldering in an oxygen-free furnace in a clean room with medical quality. The high quality of Master Sound Discrete DACs is supported by technology cultivated in the manufacturing experience of electronic circuit boards for audio, medical, aerospace, and defense applications.

Esoteric-HCLD, a unique output buffer circuit

The Esoteric-HCLD (High Current Line Driver) output buffer amplifier employs a device that boasts an astonishingly high-speed slew rate of 2,000V/μs, which represents the response speed. The most important current transmission capability and speed for analog output circuits are pursued to the limit, reproducing the reality of music with breathtaking dynamic range.

USB Audio and MQA processing

Equipped with various digital input terminals including USB for DSD 22.5MHz and asynchronous transmission, the K-05XD behaves as a D/A converter unit. This Player includes MQA technology, which enables you to play back MQA-CD and MQA audio files and streams, delivering the sound of the original master recording.



Block Diagram

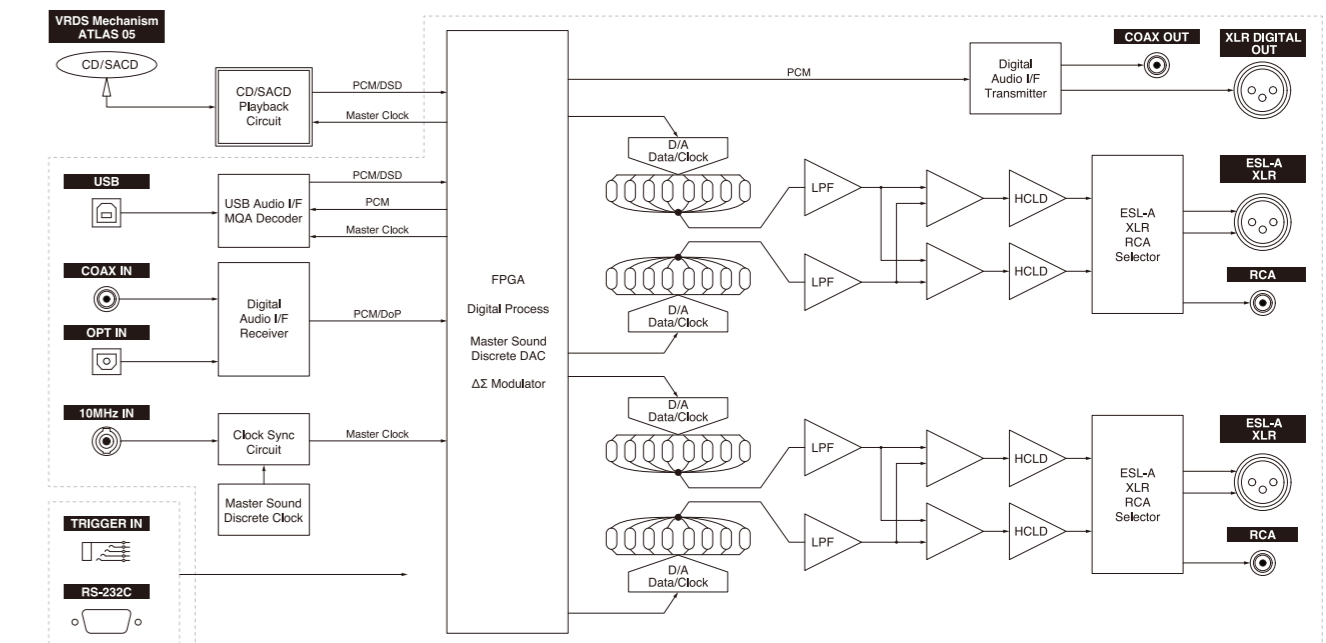

Master Sound Discrete Clock

for Digital Player



Newly developed on-board Discrete Clock for Digital Player

It is no exaggeration to say that the clock circuit is the biggest key to high sound quality in digital playback. Esoteric focused on crystal oscillator circuits, which had been previously packaged as general-purpose modules in ICs, and completed a unique manufactured clock module, the "Master Sound Discrete Clock" for the Grandioso G1X, our flagship master clock generator.



The G1X's unique discrete circuitry has earned high acclaim for its superior musical expressiveness and has caused a stir in the world of clocks, which have traditionally been described only in terms of accuracy.

The "Master Sound Discrete Clock for Digital Player" first employed here in the K-05XD, applies this discrete circuit design concept to the internal clock of a digital player, exclusively. The unique circuit design using carefully selected discrete components, such as a large crystal oscillator, achieves high sound quality that reflects Esoteric's philosophy in every detail, which cannot be achieved with a general-purpose clock IC. The K-05XD also works with an external master clock generator to upgrade the sound quality by synchronizing the internal circuits to an even higher precision 10MHz clock.

ES-Link Analog, a high-quality sound current transmission

In addition to line connections (XLR, RCA), ES-Link Analog, Esoteric's original current transmission method, is employed for connection to an amplifier. By taking advantage of the powerful current supply capability of the HCLD buffer circuit, the signal is less affected by the impedance of the signal path and can be transmitted powerfully, maximizing the potential of the compatible equipment.

ES-Link Analog – Esoteric's unique current transmission

Esoteric's unique current transmission system "ES-Link Analog" is the ideal method for audio signal transmission. Compared to the conventional voltage transmission, it transmits approximately 100 times more current, making it less susceptible to noise and sending the full energy of the music to the amplifier.

Also, it is not affected by the impedance of the interconnects running between the source device and amplifier, so it maintains a perfect integrity between the output signal of the source and the input signal to the amplifier.

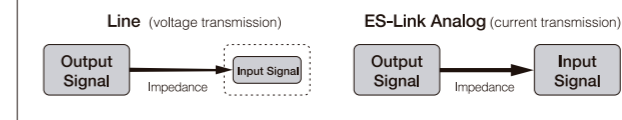

Powerful power supply, a key to sound quality

With the all-new design platform, the power supply section is enhanced to more than twice the circuit scale of the previous model, adding even more punch and depth to the tone. A total of two high-capacity toroidal transformers are installed to provide independent digital and analog power supplies. In addition, a separate EI core power transformer dedicated to the control section provides lower noise and purer reproduction capability.

New low feedback DC regulator/supercapacitor

The power supply regulator is a discrete configuration that does not use integrated circuits in key parts, and employs a "Low-feedback DC regulator" that minimizes the amount of feedback to achieve a powerful and open sound. In addition, the K-05XD is equipped with a total of 16 supercapacitors (total capacitance: 250,000 μ F = 0.25F). By increasing the capacitance of the power supply, the resolution of the low range has been greatly improved.

Double-face remote control

A compact and simple remote control is included that can also operate Esoteric amplifiers. The functional design features buttons used for each operation scenario on both sides of the remote control and the smartphone-sized aluminum body, which fits comfortably in the hand.



Top

Bottom



Double-face Remote
RC-1333 included

K-05XD Super Audio CD/CD Player



Analog Audio Outputs: ES-Link Analog /XLR x 1 pair
RCA x 1 pair

Digital Audio Outputs: XLR x 1
Coaxial x 1

Digital Audio Inputs: Coaxial x 1
Optical x 1
USB x 1

Clock Input: BNC x 1

Frequency Response: 5Hz to 70kHz (-3dB)*

S/N Ratio: 110dB (IHF-A)*

Total Harmonic Distortion: 0.0007% (1kHz)*

Power: 120V AC 60Hz, 220-240V AC 50Hz

Overall Dimensions (WxHxD): 445 x 161 x 357 mm (include protrusions)

Weight: 20.7 kg

* SACD 0dB, DSD: F2, XLR out

Key Features

- Newly designed VRDS-ATLAS "ATLAS 05" Super Audio CD Transport mechanism
- "Master Sound Discrete DAC" – In-house developed FPGA, 64bit/512Fs Delta-Sigma modulator
- "Master Sound Discrete Clock for Digital Player" – in-house discrete clock module
- Our proprietary "ES-Link Analog" current signal transmission output
- "Esoteric-HCLD" output buffer amplifier (slew rate: 2,000V/μs)
- 3 power supply transformers (two toroids for analog, digital and one EI for control)
- Low-feedback DC regulator
- 10MHz external clock input
- Equipped with MQA decoder
- USB DAC function (DSD 22.5MHz / Asynchronous transmission capability)
- Various in/out terminals;
 - Digital inputs: coaxial, optical (192kHz & DoP)
 - Digital outputs: XLR, coaxial
- Selectable digital filter options for PCM, analog FIR filter on/off function for DSD
- RS-232C port, trigger on/off control
- RC-1333 remote controller that can also control Esoteric amplifiers.

- This product is available in two different power supply variations as shown in the chart above. Make sure that the voltage shown on the rear panel matches the AC line voltage in your area.
- The shape of the AC inlet and plug of the supplied power cord depends on the voltage rating and destination country.

©2024 TEAC Corporation. All Rights Reserved. All text, images, graphics and other materials on this brochure are subject to the copyright and other intellectual property rights of TEAC Corporation. These materials shall not directly or indirectly be published, reproduced, modified or distributed in any medium. Esoteric, Grandioso, and VRDS are trademarks of TEAC Corporation, registered in the U.S. and other countries. Master Sound Discrete DAC is a registered trademark of TEAC Corporation. "DSD" is a registered trademark. All other brand or product names are trademarks or registered trademarks of their respective holders.

TEAC Corporation

1-47, Ochiai, Tama-shi, Tokyo Japan 206-8530

Esoteric Brand Website ▶
<https://www.esoteric.jp/en>



Authorized Dealer